



PUMA HT/QL series

Twin Spindle Turning Center & Gantry Loader series



Two Spindle, 4-axes Turning Center Realizes Twice the Productivity

**PUMA HT230T / H250T / H310T
PUMA H250TM / H310TM**



Integral CNC Gantry Loader Ensures Versatile Automation and High Productivity

PUMA HT230TG / QL200H / QL300H
PUMA QL200HM / QL300HM



Main Spindle



Main spindle is supported by high precision bearing combination with large diameter. All spindle bearing are lubricated by grease.

C-axis contouring provides main spindle positioning in increments of 0.001 degree. Three dimensional contouring, complex round and prismatic machining, square shoulder and lettering are accomplished by synchronizing the spindle with linear axes (on H250TM / H310TM / QL200HM / QL300HM)

PUMA HT230T / HT230TG series (6" class)

Max. spindle speed Motor (15/30min)

4500 r/min **11/7.5** kW
(14.8/10.1 Hp)

PUMA H250T / QL200H series (8" class)

Max. spindle speed Motor (30min)

4500 r/min **11** kW (14.8 Hp)

PUMA H310T / QL300H series (10" class)

Max. spindle speed Motor (30min)

3500 r/min **18.5** kW (24.8 Hp)

C-axis control of main spindle

C-axis index

360° (in 0.001° increment)

C-axis braking torque

141 N·m (104.1 ft·lb) (H250TM / QL200HM)

319 N·m (235.4 ft·lb) (H310TM / QL300HM)

C-axis contouring torque

112 N·m (82.7 ft·lb) (H250TM / QL200HM)

393 N·m (290.0 ft·lb) (H310TM / QL300HM)

Machining Application

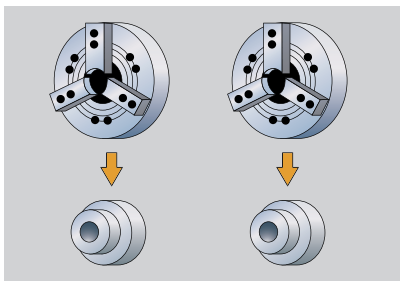

Turning Identical Parts on Both Spindles

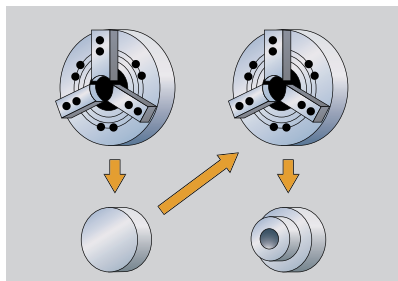

First Step on Left Spindle & Second Step on Right Spindle

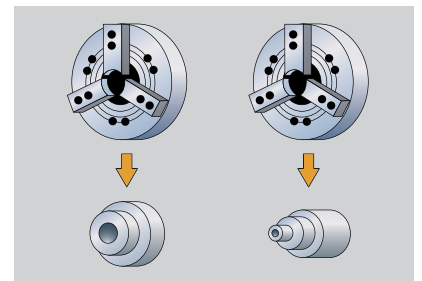

Turning Different Parts on Spindle

Main Spindle Power-torque Diagram

PUMA HT230T **std.**

- Max. spindle speed : 4500 r/min
- Motor power : 11 kW (14.8 Hp)

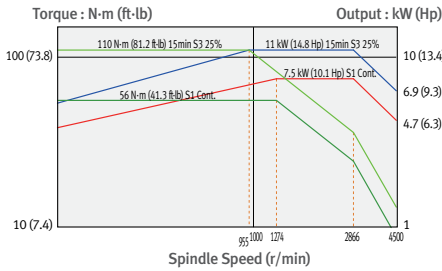

PUMA HT230T **opt.**

- Max. spindle speed : 6000 r/min
- Motor power : 11 kW (14.8 Hp)

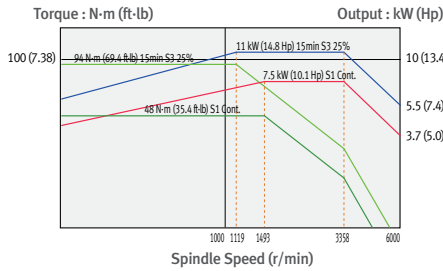

PUMA HT230T **opt.**

- Max. spindle speed : 4500 r/min
- Motor power : 15 kW (20.1 Hp)

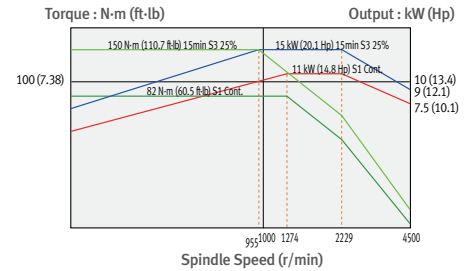

PUMA HT230TG **std.**

- Max. spindle speed : 4500 r/min
- Motor power : 7.5 kW (10.1 Hp)

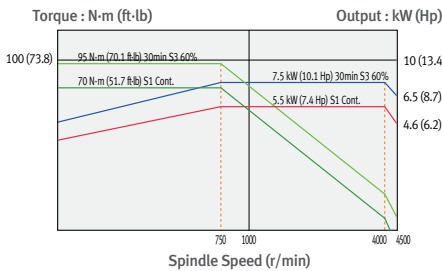

PUMA HT230TG **opt.**

- Max. spindle speed : 6000 r/min
- Motor power : 7.5 kW (10.1 Hp)

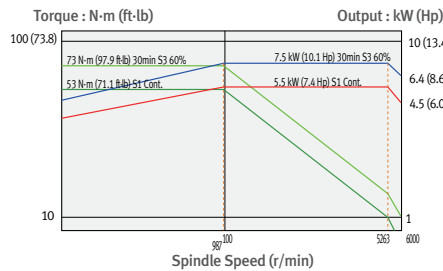

PUMA HT230TG **opt.**

- Max. spindle speed : 4500 r/min
- Motor power : 15 kW (20.1 Hp)

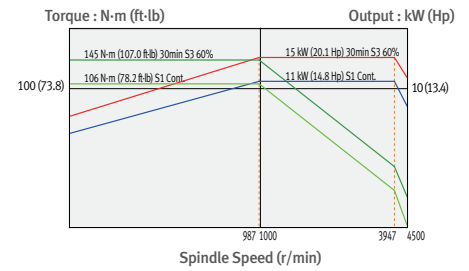

PUMA H250T [TM] / QL200H [HM] **std.**

- Max. spindle speed : 4500 r/min
- Motor power : 11 kW (14.8 Hp)

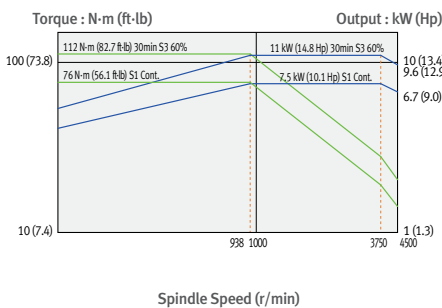

PUMA H250T [TM] / QL200H [HM] **opt.**

- Max. spindle speed : 4000 r/min
- Motor power : 15 kW (20.1 Hp) (High / Low winding)

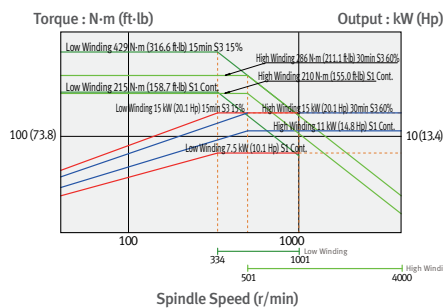

PUMA H250T [TM] / QL200H [HM] **opt.**

- Max. spindle speed : 4500 r/min
- Motor power : 15 kW (20.1 Hp) (High / Low winding)

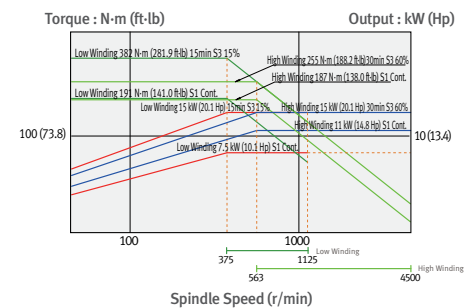

PUMA H310T [TM] / QL300H [HM] **std.**

- Max. spindle speed : 3500 r/min
- Motor power : 18.5 kW (24.8 Hp)

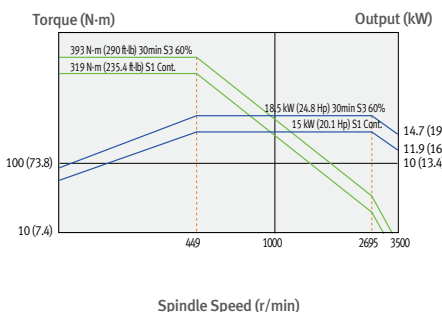

PUMA H310T [TM] / QL300H [HM] **opt.**

- Max. spindle speed : 3500 r/min
- Motor power : 18.5 kW (24.8 Hp) (High / Low winding)

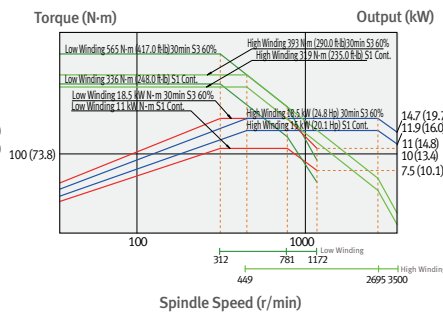

PUMA H310T [TM] / QL300H [HM] **opt.**

- Max. spindle speed : 3500 r/min
- Motor power : 22 kW (29.5 Hp)

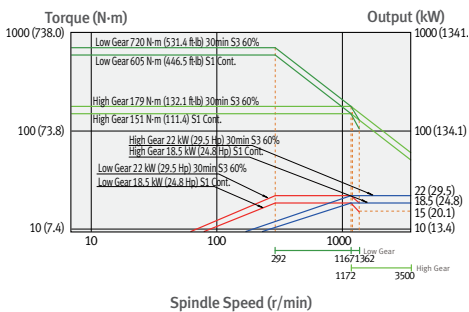

Turret



The heavy duty design provides unsurpassed rigidity for heavy stock removal, fine surface finishes, Turning tools are securely attached to the turret by wedge clamps.

Index time (1-station swivel)

HT230T / HT230TG : **0.25 s**

H250T [TM] / QL200H [HM] : **0.3 s**

H310T [TM] / QL300H [HM] : **0.35 s**

2 axis V10 turret

No. of tool station

Left 10 + Right 10

HT230T / H250T / H310T / HT230TG /
QL200H / QL300H

Rotary tool spindle power-torque diagram

PUMA H250TM / QL200HM

- Max. tool spindle speed : 3000 r/min
- Motor power : 3 kW (4.0 Hp)

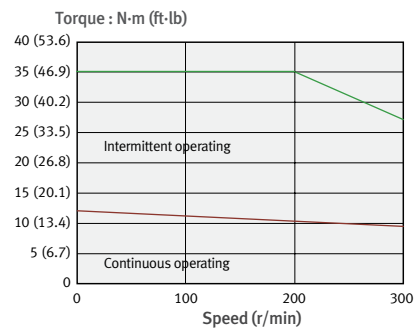

PUMA H310TM / QL300HM

- Max. tool spindle speed : 3000 r/min
- Motor power : 4 kW (5.4 Hp)

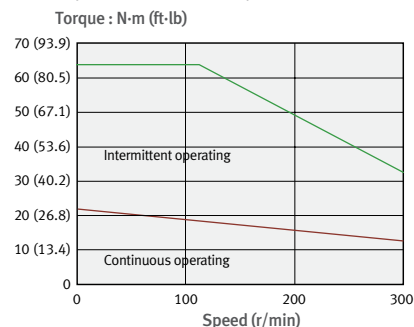

3 axis BMT / VDI turret

Total 24 tool stations turret (VDI) make it possible to complete complicated parts requiring many tools in just one set-up.

No. of tool station (H250TM / H310TM / QL200HM / QL300HM)

Left 12 + Right 12

H250TM / QL200HM **BMT55**

H310TM / QL300HM **VDI 40**



< BMT turret >



< VDI turret >

Machine Construction

All guide ways are wide wrap-around rectangular type for unsurpassed longterm rigidity and accuracy

Exclusive bed design provides exceptional accessibility to the chuck for convenient loading / unloading of parts. Separated left and right bed minimizes the effect of vibration in various cutting conditions and realize the high reliability.

For H250T / TM

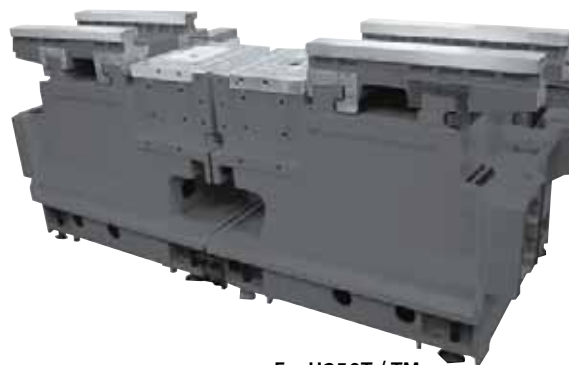

For H250T / TM

Working Range

A : Max.turning dia.

240 mm (9.4 inch) (HT230T)

260 / 310 mm (10.2 / 12.2inch) (H250T / TM)

410 mm (16.1 inch) (H310T / TM)

B : Max.turning Length

165 mm (6.5 inch) (HT230T)

200 mm (7.9 inch) (H250T / TM)

230 mm (9.1 inch) (H310T / TM)

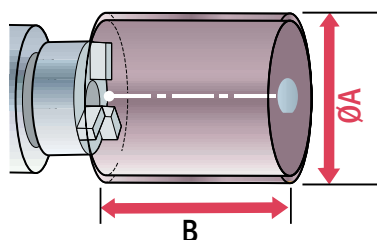
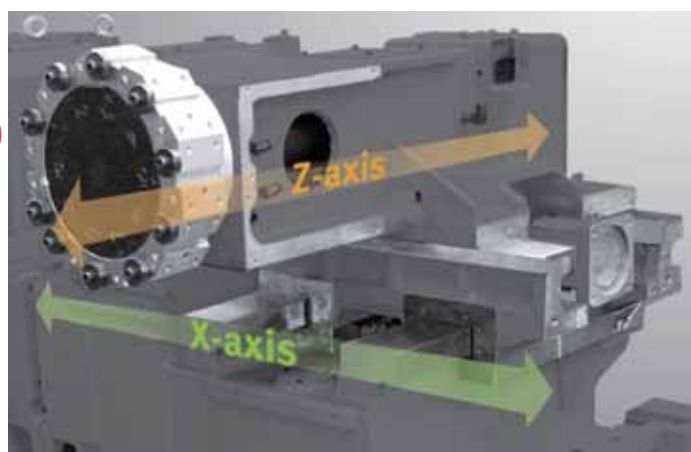

Left and Right side have the same working capacity.

Axis travel
(HT230T / H250T / H310T)

X-axis **140 / 180 / 210** mm
(5.5 / 7.1 / 8.3 inch)

Z-axis **165 / 200 / 230** mm
(6.5 / 7.9 / 9.1 inch)

Rapid travel
(HT230T / H250T / H310T)

24 m/min
(0.9 ipm)

24 m/min
(0.9 ipm)

Gantry Loader Application

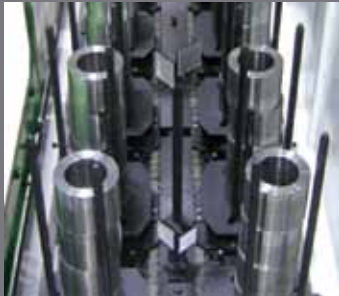

PUMA HT230TG / QL200H [HM] / QL300H [HM]

Twin spindles and Twin turrets
The machine realizes high productivity

From transmissions to four corner components which have any different shape, size and capacity are capable to be manufactured by Gantry Loader System.



FOUR CORNERS



TRANSMISSIONS



Variation of Gantry Loader Application (PUMA HT230TG / QL200H [HM] / QL300H [HM])

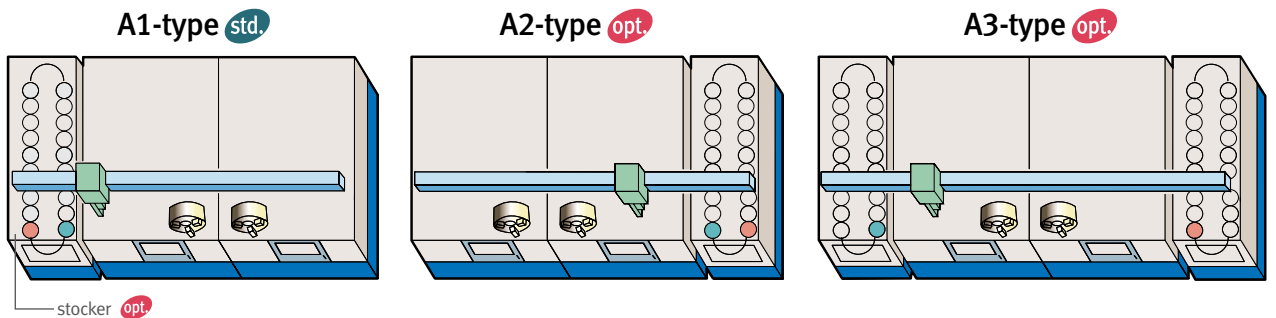

(● Loading position, ● Unloading position)

Gantry Loader

Axis travel of Gantry loader*

PUMA HT230TG / QL200H [HM] / QL300H [HM]

X-axis **1850 / 2010 / 3105** mm
(72.8 / 79.1 / 122.2 inch)

Y-axis **545 / 700 / 945** mm
(21.5 / 27.6 / 37.2 inch)

Z-axis **180 / 200 / 200** mm
(7.1 / 7.9 / 7.9 inch)

* : Axis travel of gantry loader is for A1-type gantry loader application

Servo driven CNC gantry loader

PUMA HT230TG / QL200H [HM] / QL300H [HM]

: 3-axis Servo driven (X, Y, Z)

Max. G-Loader Handling Size (Max. turning dia.×Max. turning length)		
PUMA HT230TG Ø140×100	PUMA QL200H/HM Ø160×115	PUMA QL300H/HM Ø250×150

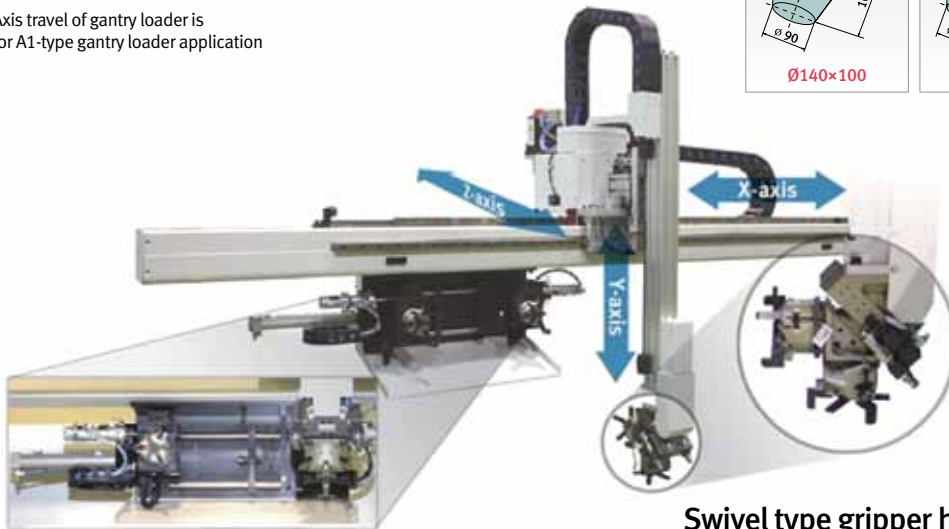

Swivel type gripper head
Wrist swivel angle : **180°**

Ergonomic Design

Easy chip disposal

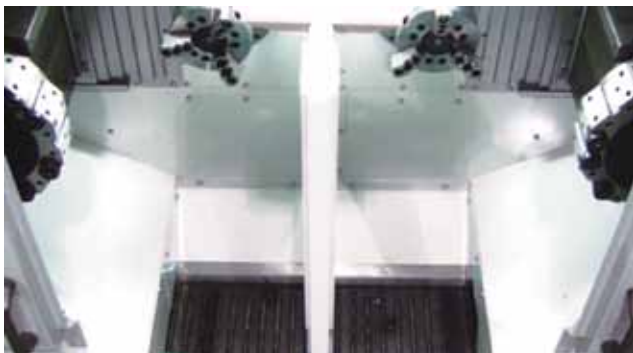

A large capacity chip pan is installed separately from the machine bed so that heat generated by cut chips will not distort the bed. The large coolant capacity allows a constant coolant temperature to be maintained for precision machining.

Accessibility

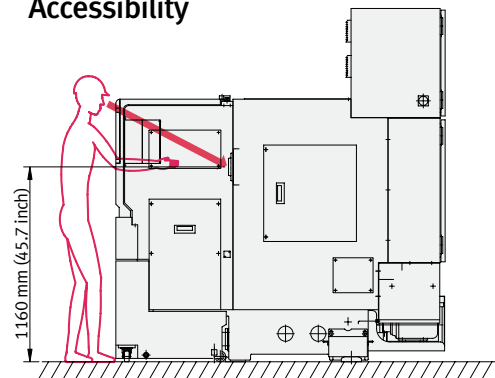

Easy accessibility to setup work pieces and tools which ensures operation efficiency.

Tooling System

unit : mm (inch)

PUMA HT230T / HT230TG

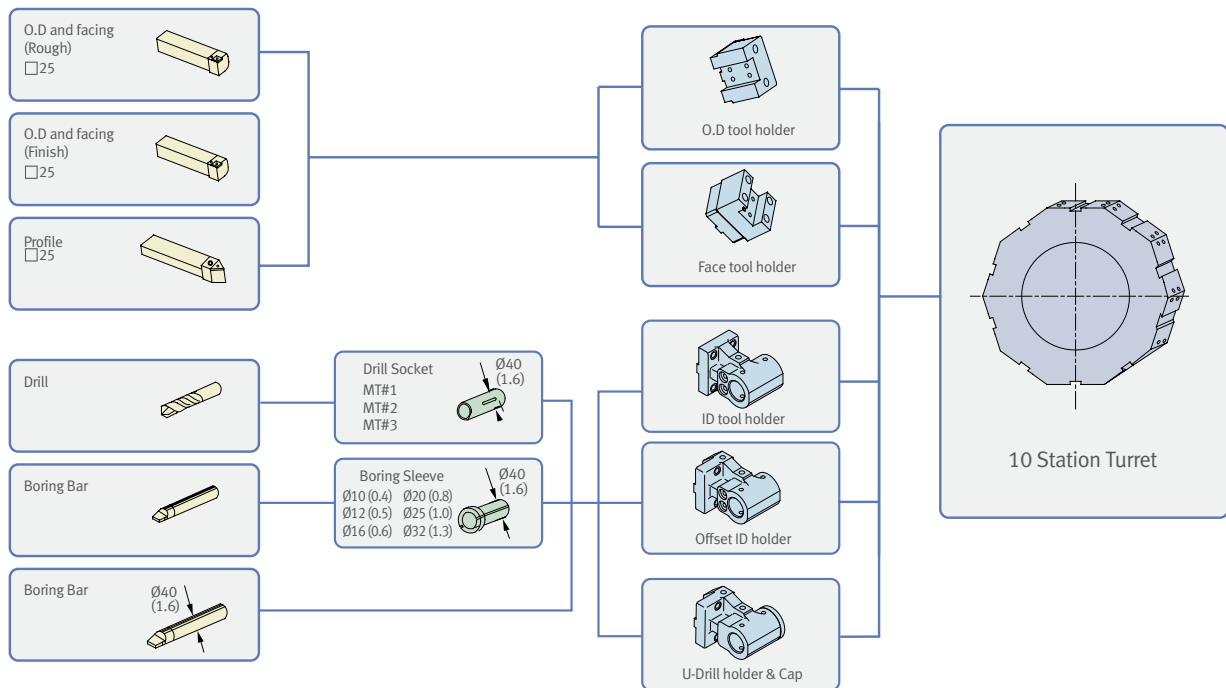

PUMA H250T / QL200H

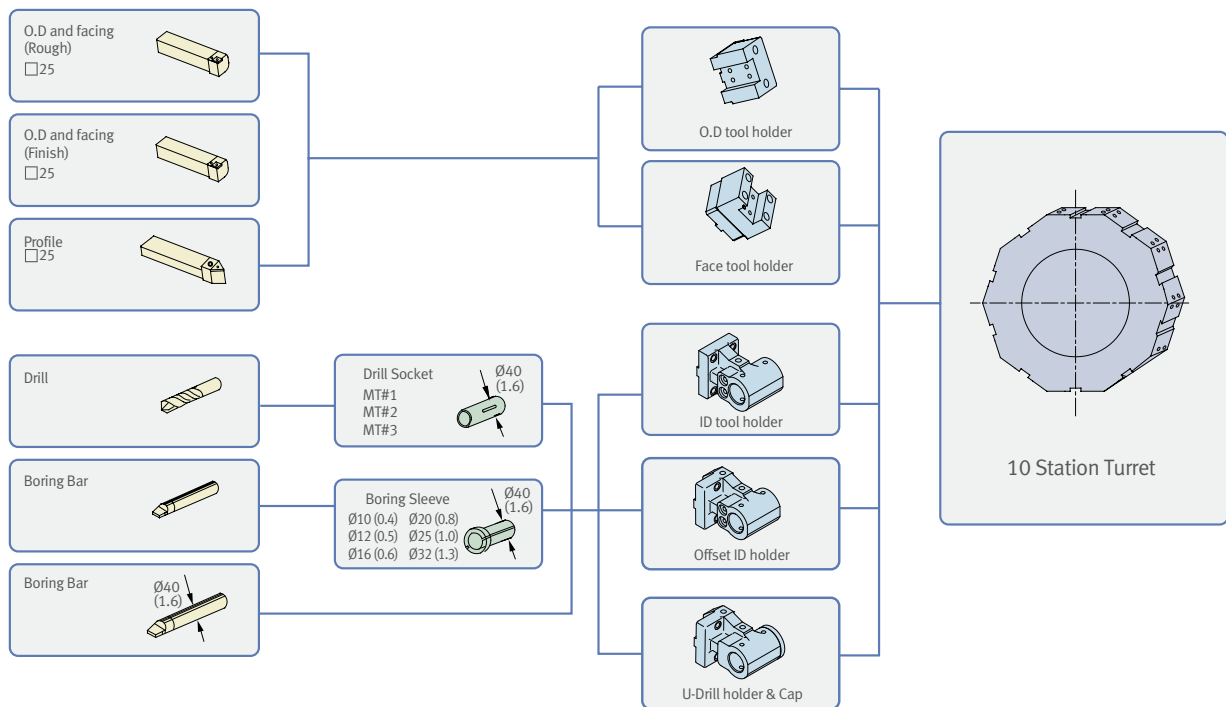

Note) Above tooling system is our recommendation. Depending on export condition, the standard tooling packed with the machine can be different.

PUMA H310T / QL300H

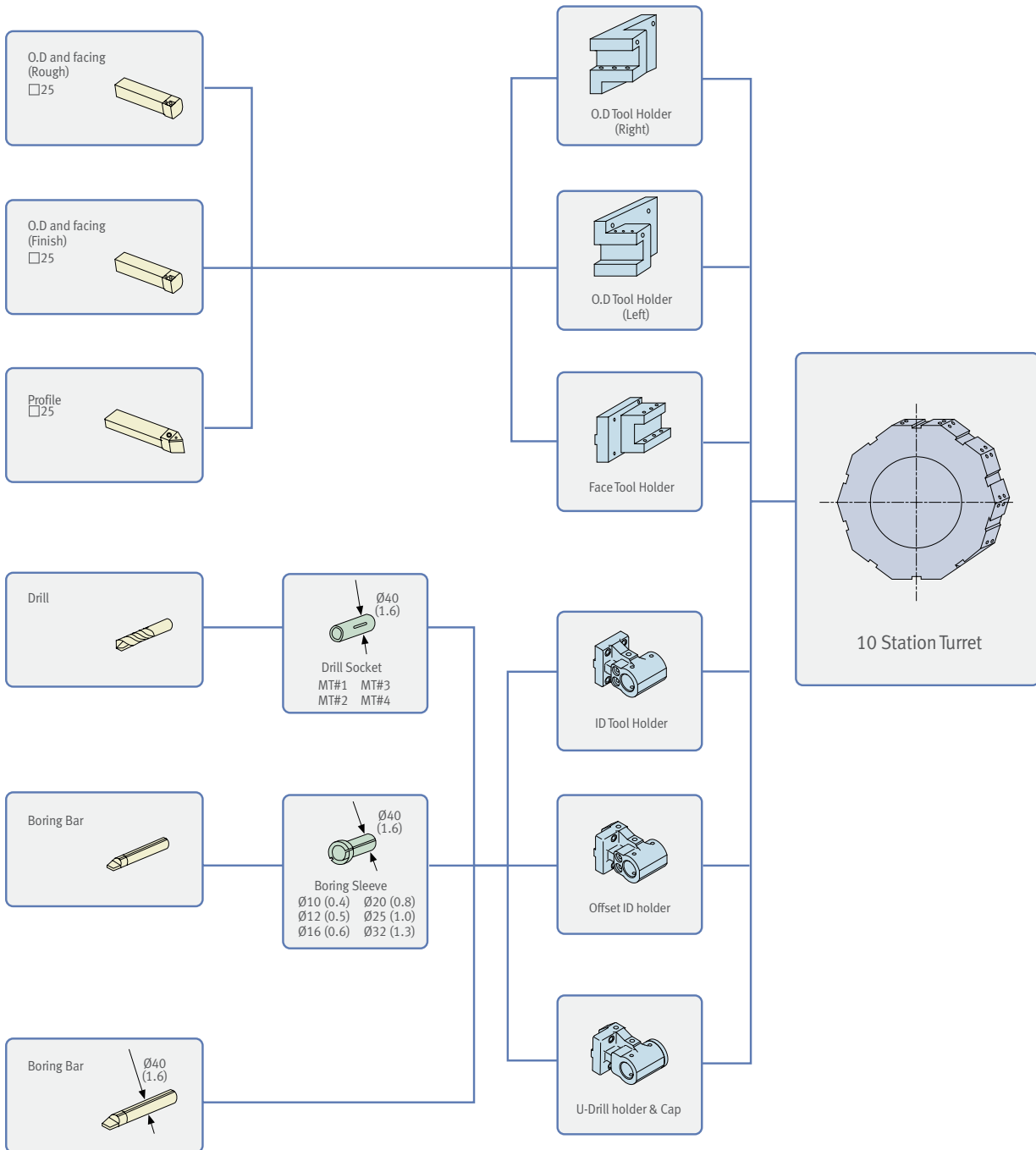

Note) Above tooling system is our recommendation. Depending on export condition, the standard tooling packed with the machine can be different.

Tooling System

unit : mm (inch)

PUMA H250TM / QL200HM

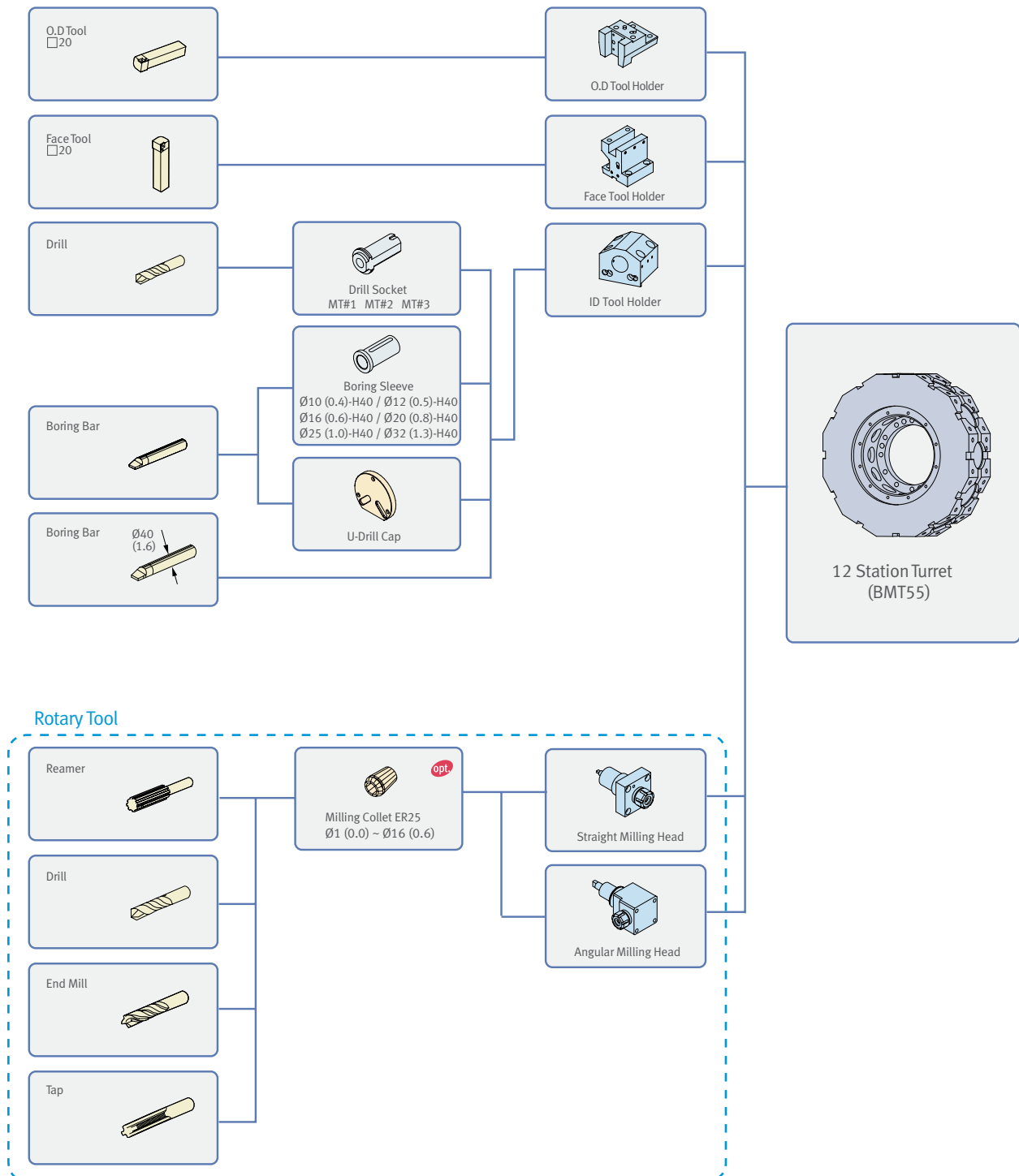

Note) Above tooling system is our recommendation. Depending on export condition, the standard tooling packed with the machine can be different.

PUMA H310TM / QL300HM

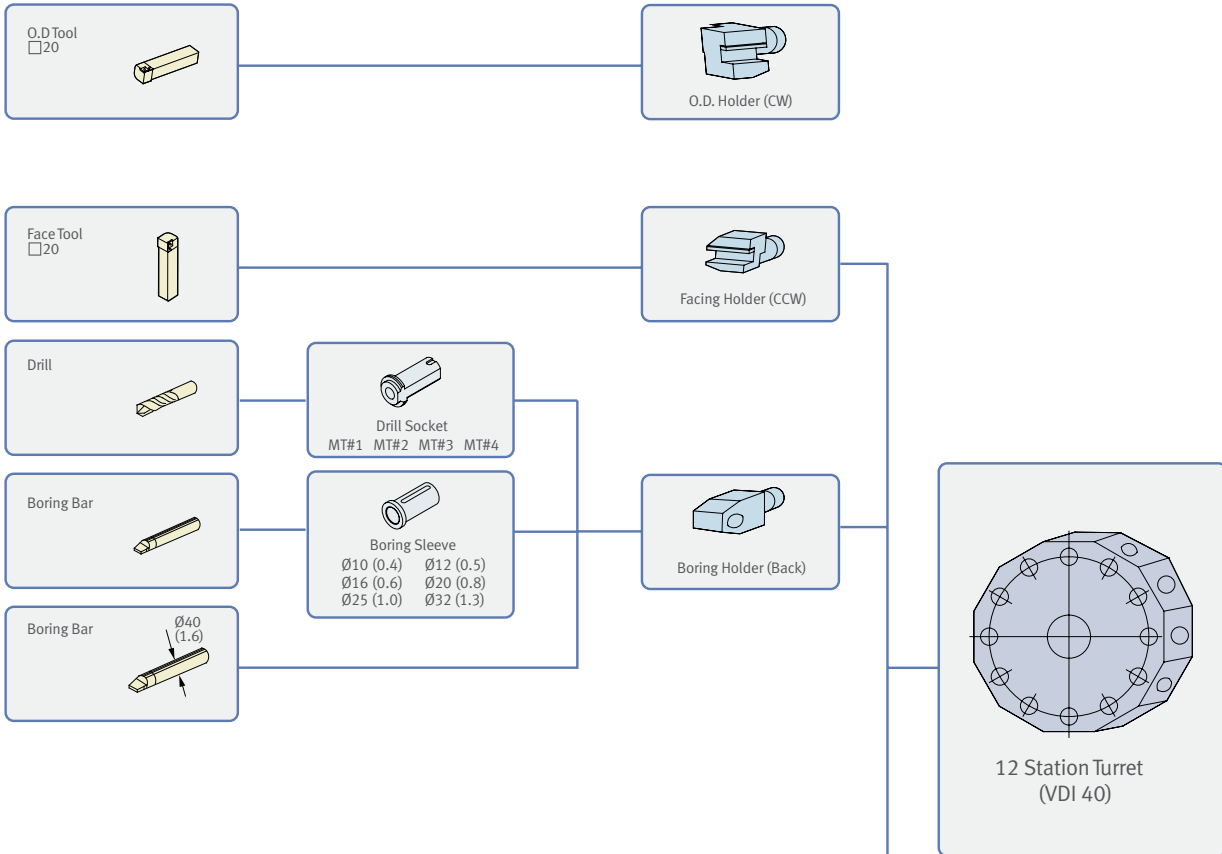

Rotary Tool

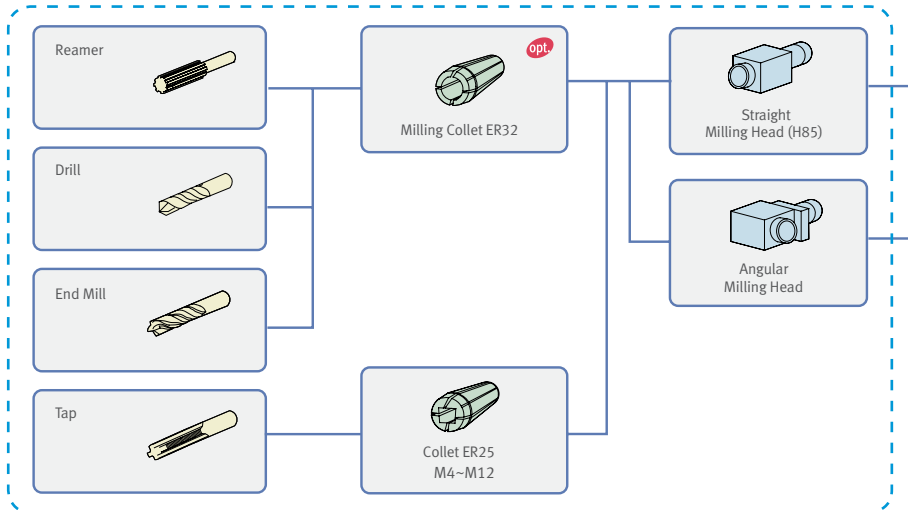

Note) Above tooling system is our recommendation. Depending on export condition, the standard tooling packed with the machine can be different.

Tool Interference Diagram

unit : mm (inch)

PUMA HT230T / HT230TG

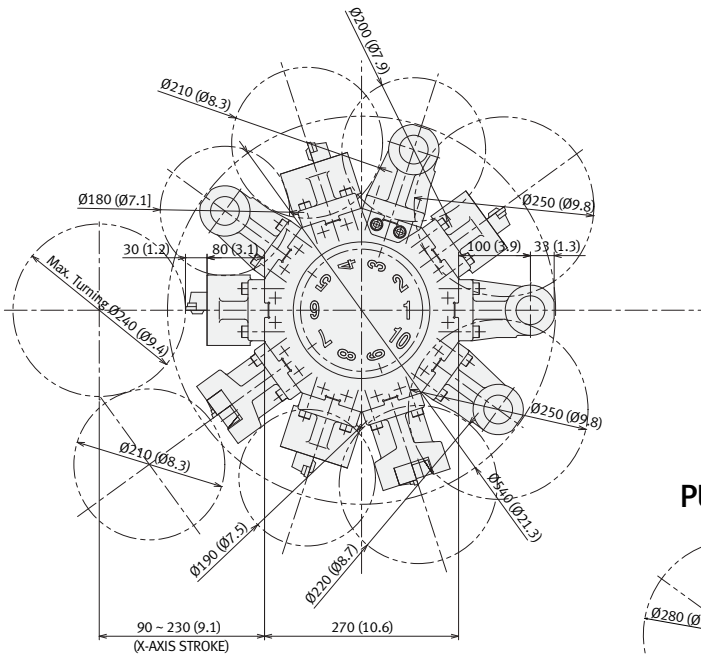

PUMA H250T / QL200H

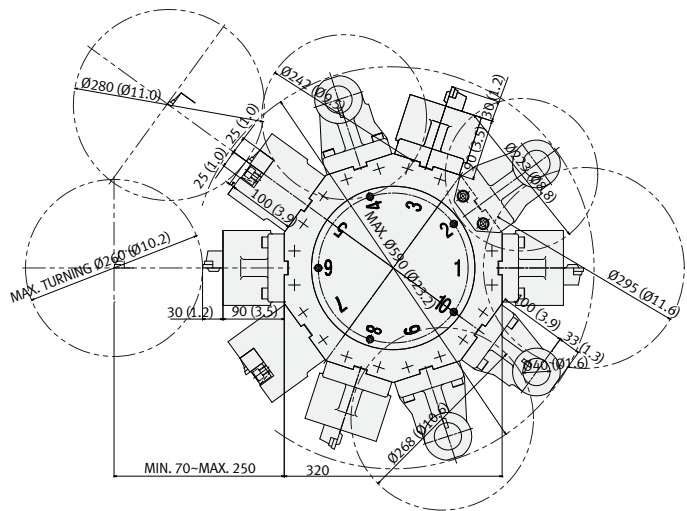

PUMA H310T / QL300H

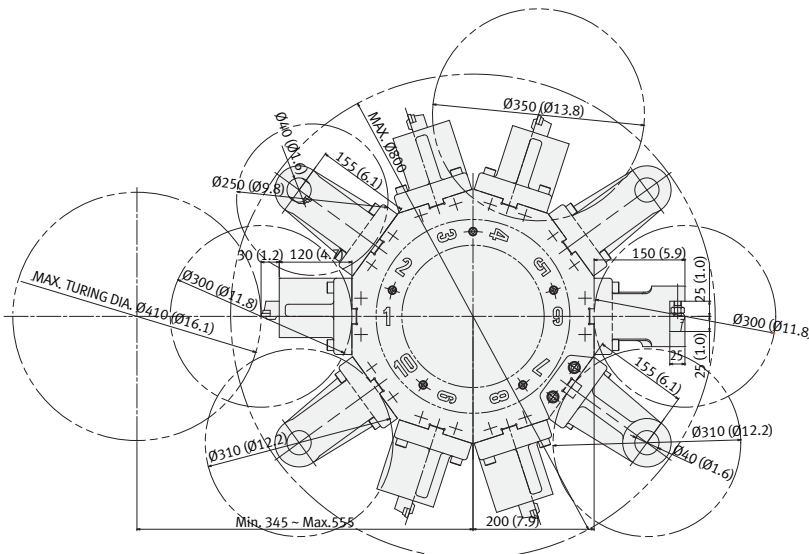

unit : mm (inch)

PUMA H250TM / QL200HM

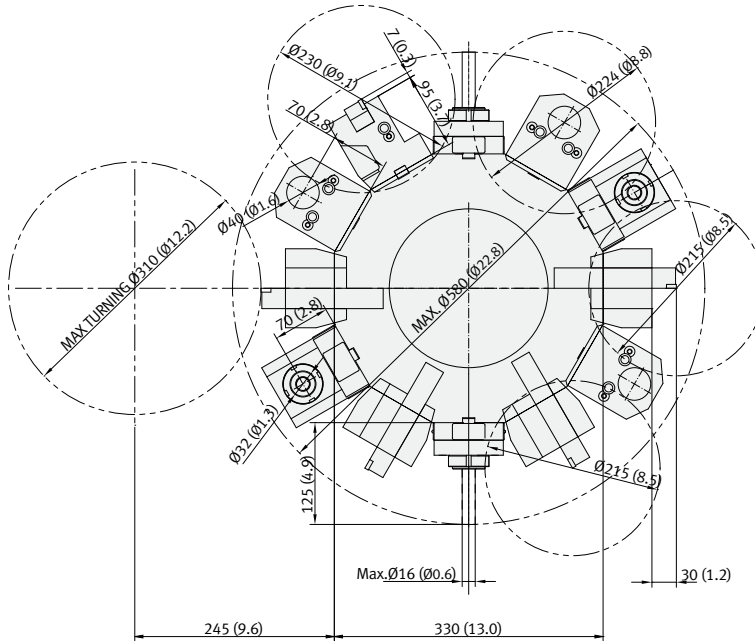

PUMA H310TM / QL300HM

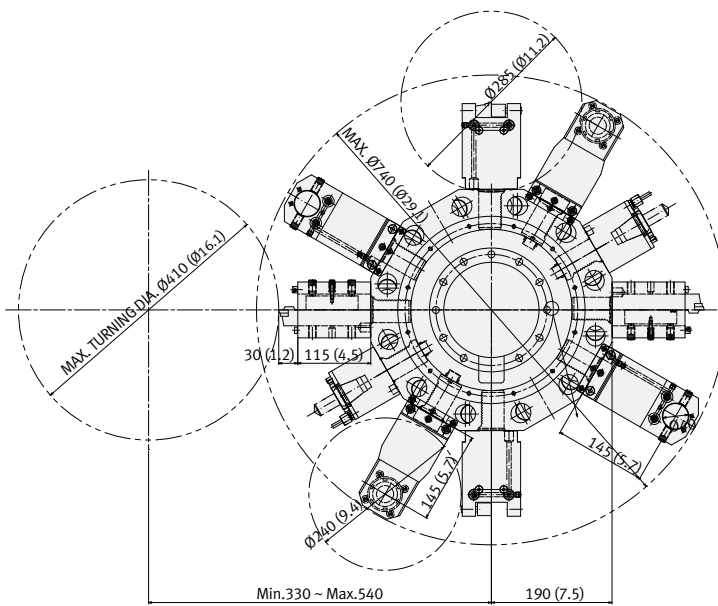

Working Range

unit : mm (inch)

PUMA HT230T / HT230TG

Axis Travel

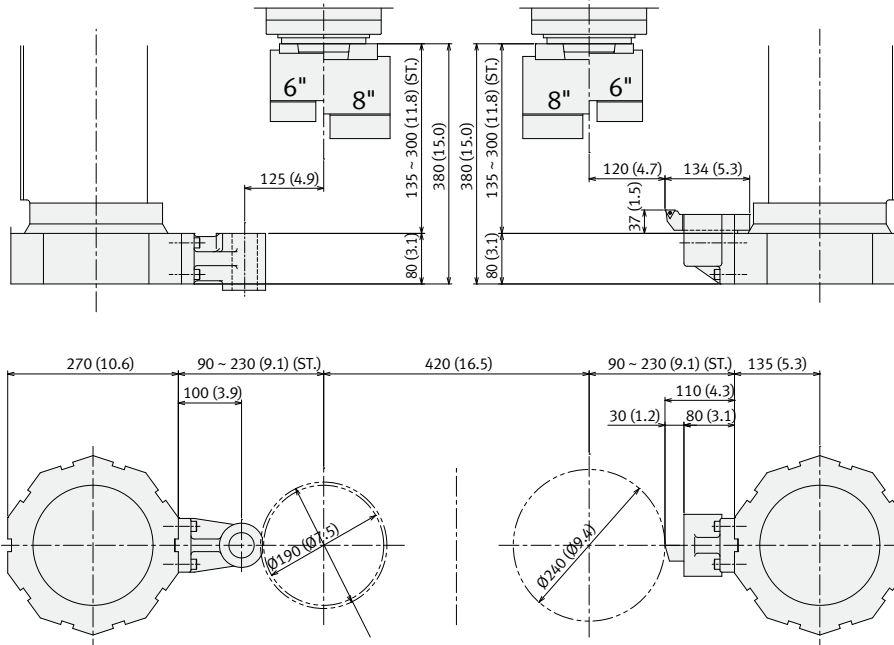

O.D Cutting

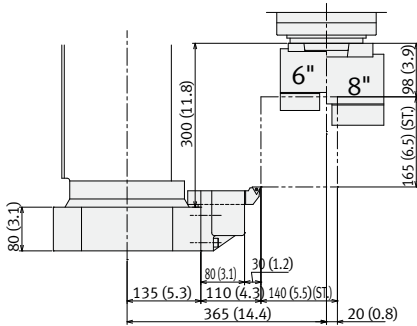

Face Cutting

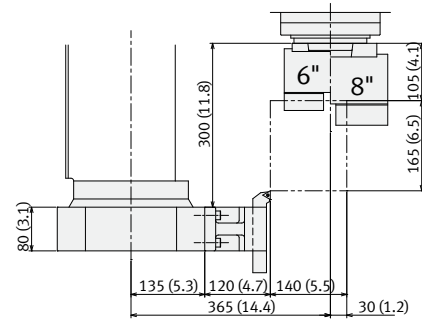

Boring

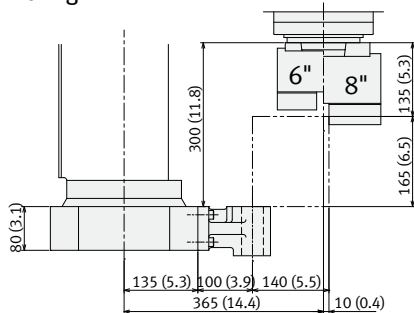

Boring

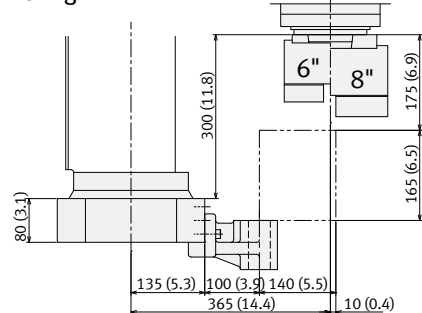

PUMA H250T / QL200H

unit : mm (inch)

Axis Travel

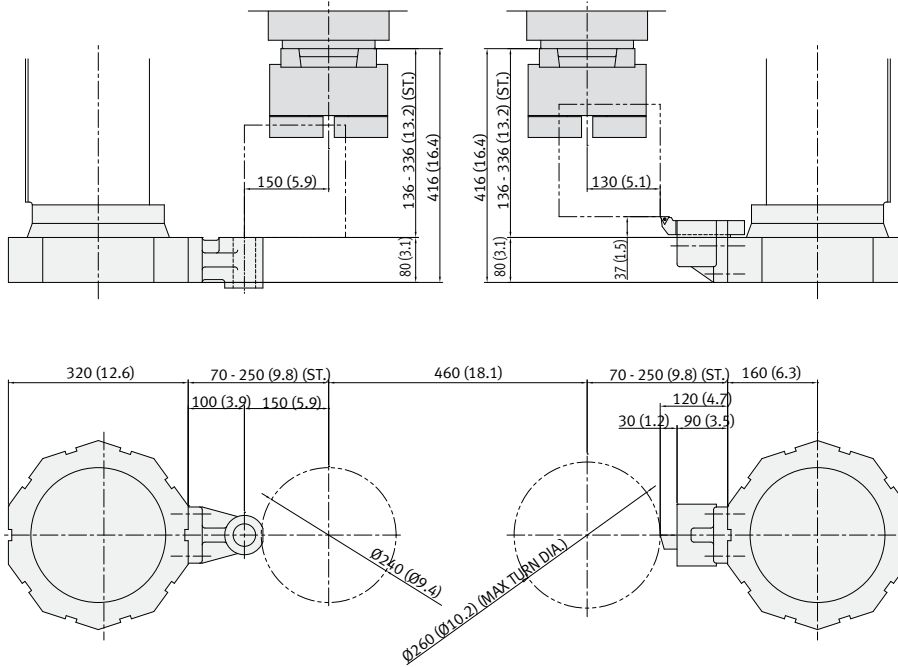

O.D Cutting

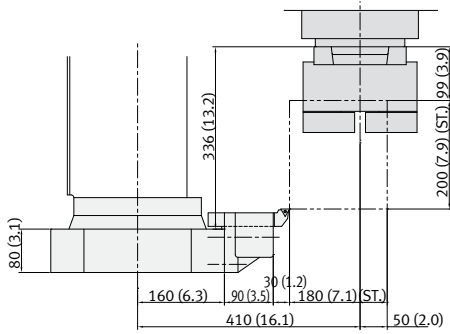

Face Cutting

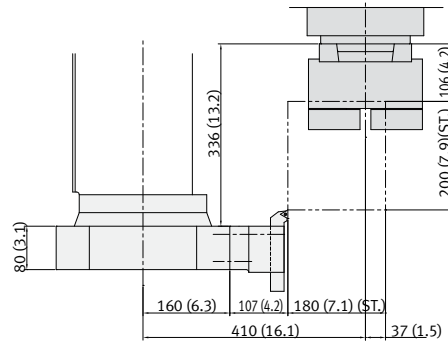

Boring

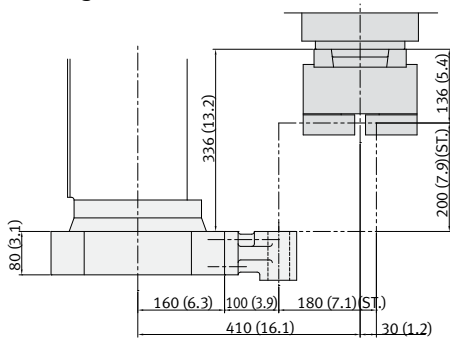

Boring

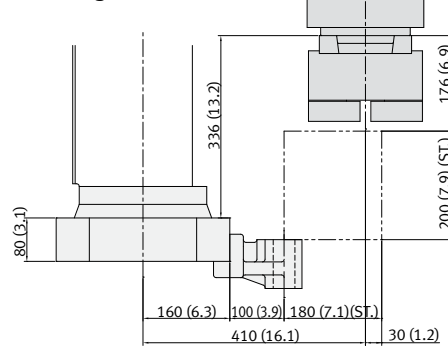

Working Range

unit : mm (inch)

PUMA H310T / QL300H

Axis Travel

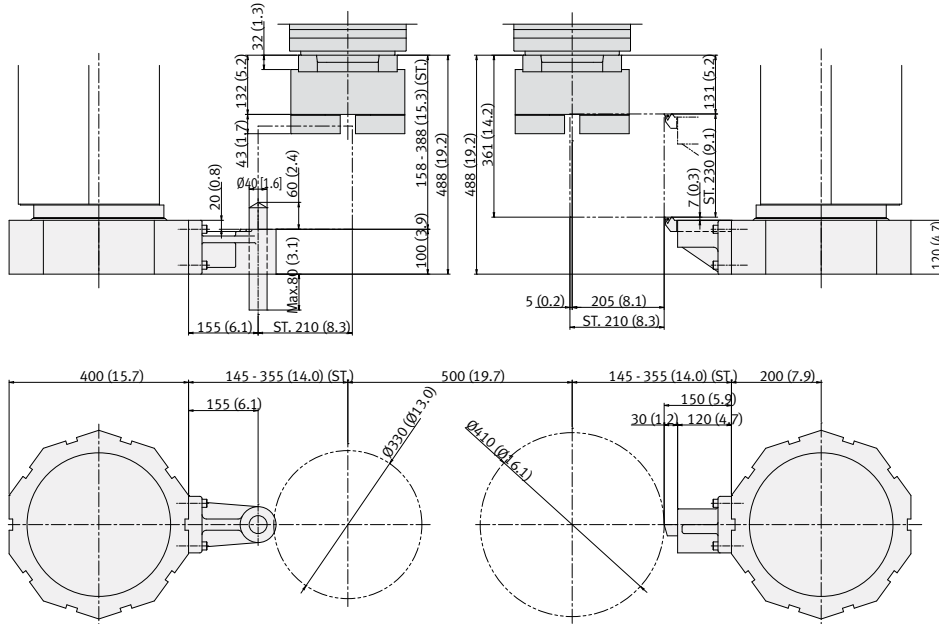

O.D Cutting

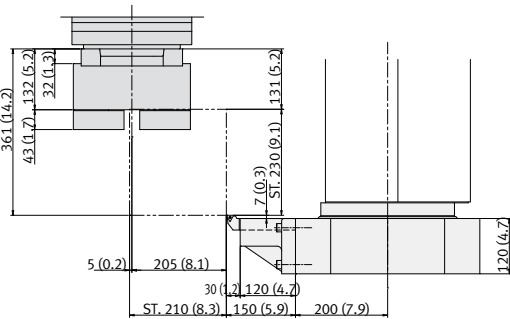

Face Cutting

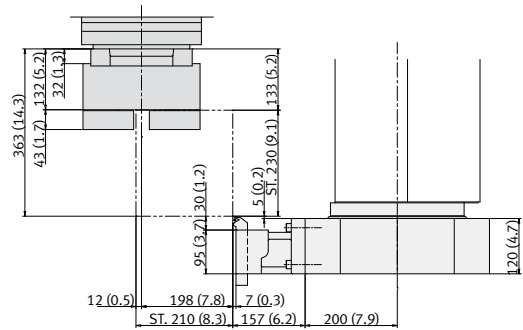

Boring

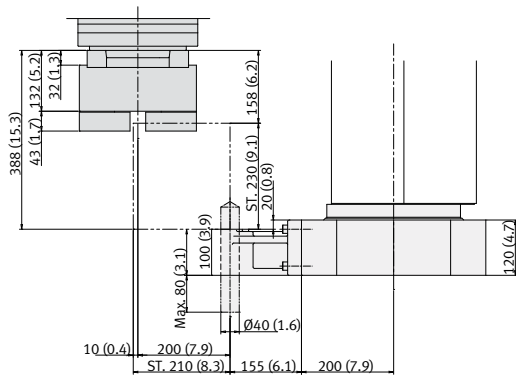

Boring

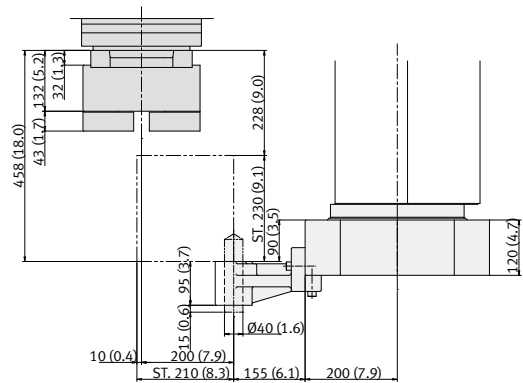

PUMA H250TM / QL200HM

Axis Travel

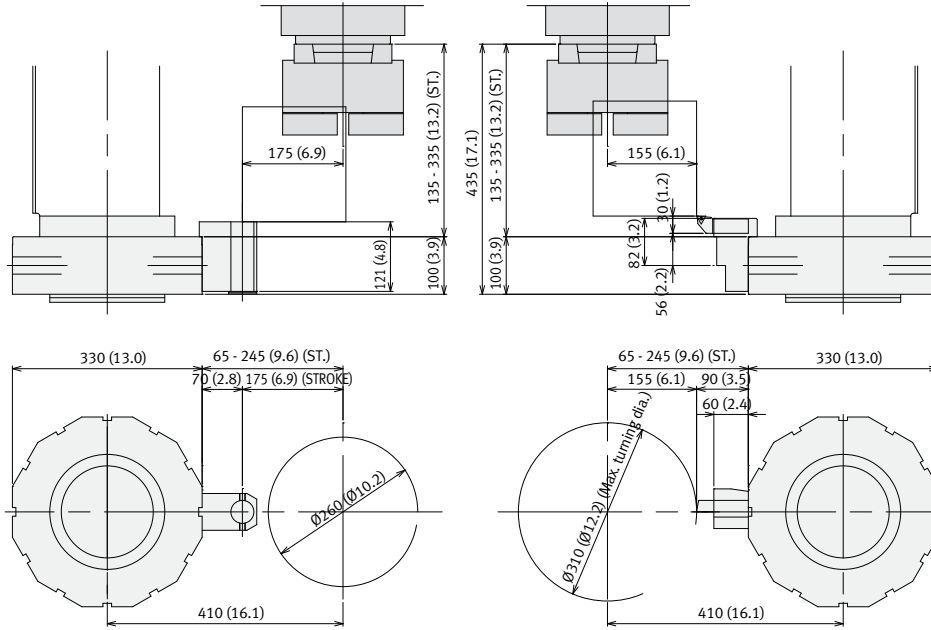

O.D Cutting

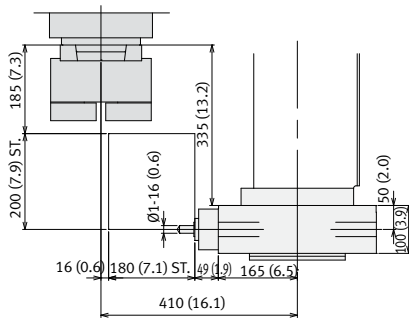

Face Cutting

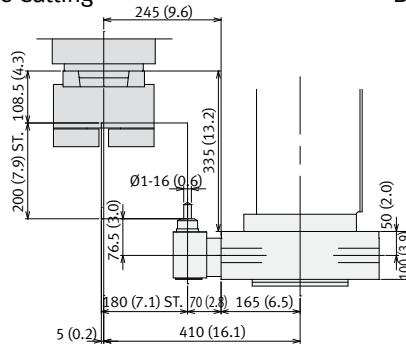

Boring

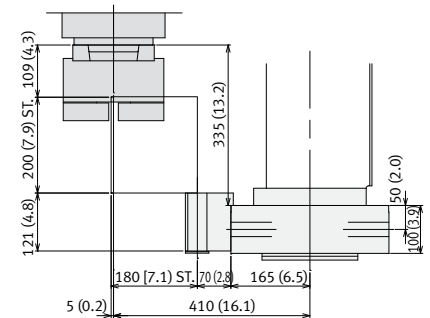

Angular milling head

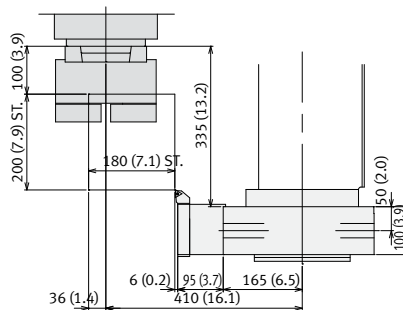

Straight milling head

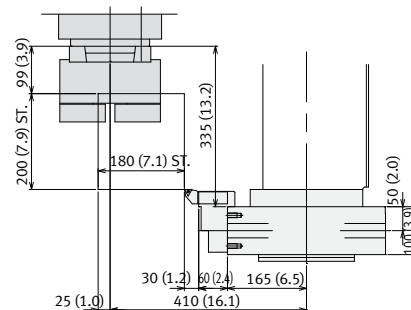

Working Range

PUMA H310TM / QL300HM

unit : mm (inch)

Axis Travel

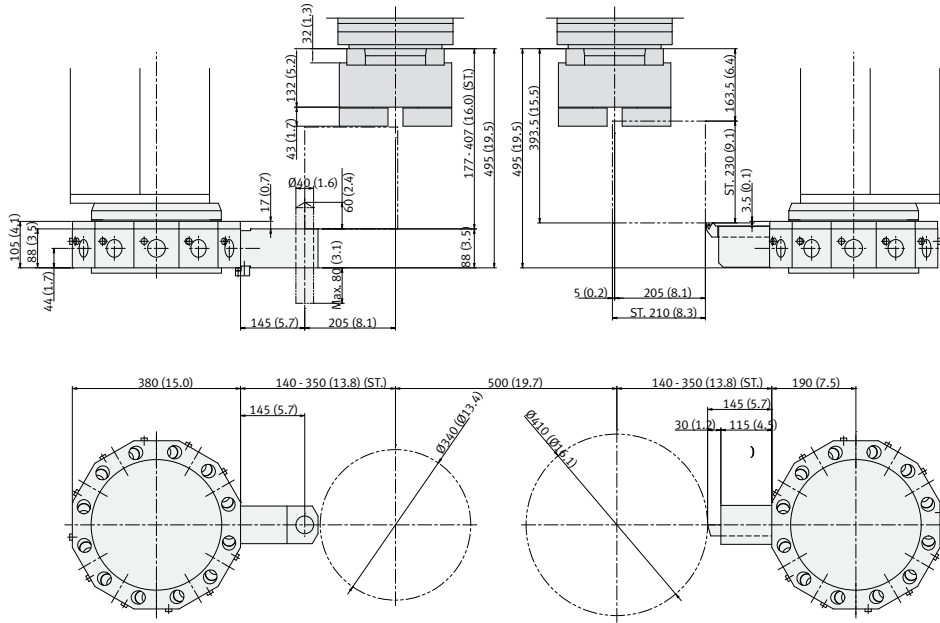

O.D Cutting

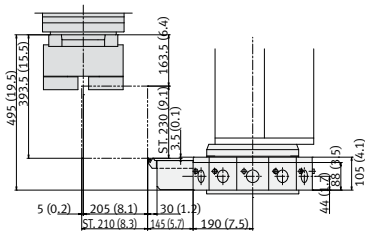

Face Cutting

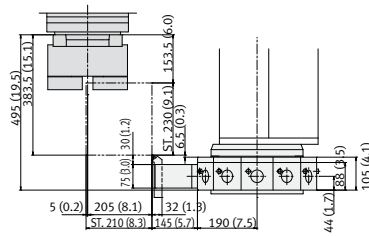

I.D (Cutting)

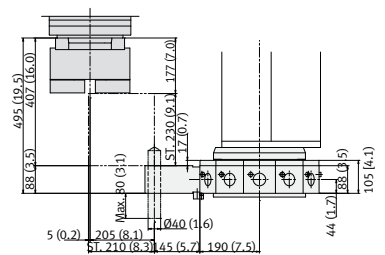

I.D (OFFSET) Cutting

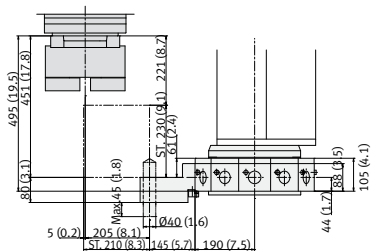

Angular milling head

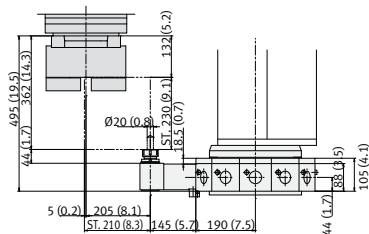

Straight milling head

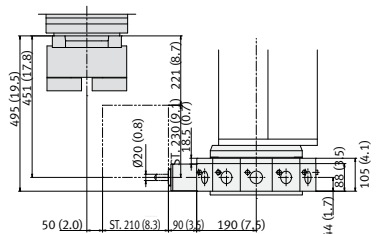

External Dimension

unit : mm (inch)

PUMA HT230T

Top View

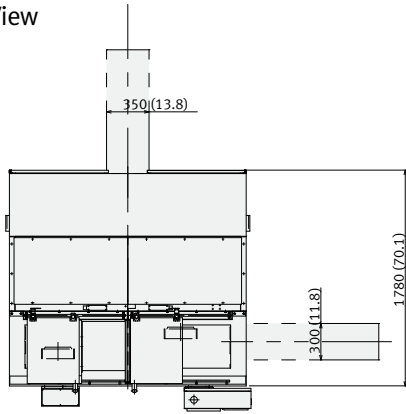

Front View

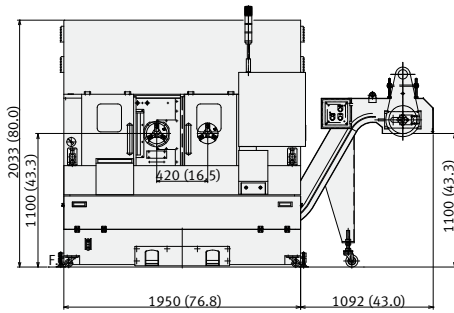

Side View

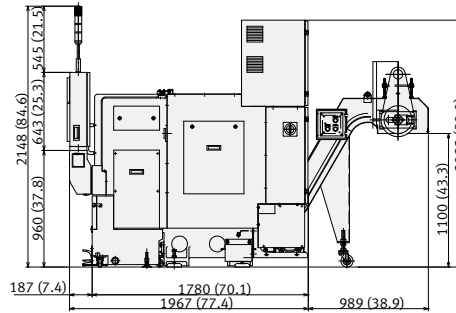

PUMA H250T / H250TM

Top View

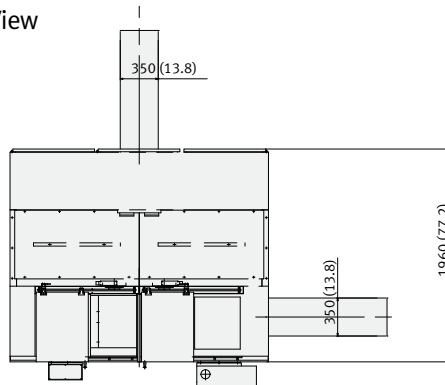

Front View

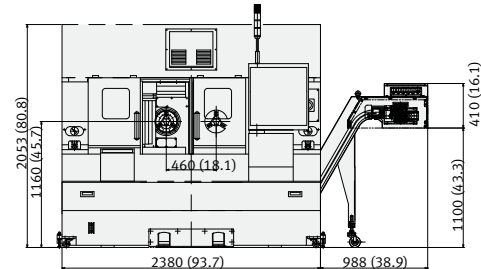

Side View

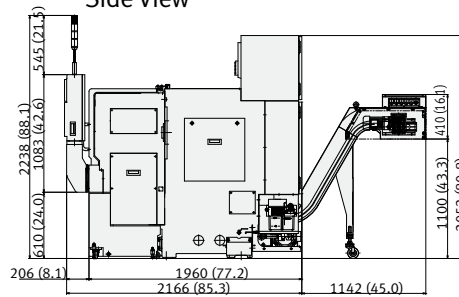

External Dimension

unit : mm (inch)

PUMA H310T / 310TM

Top View

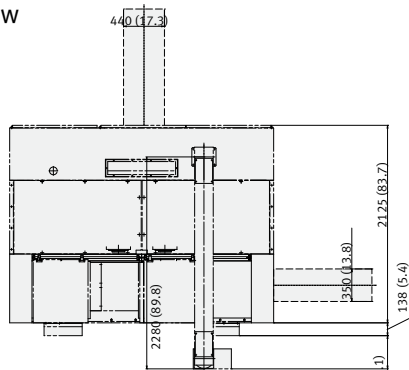

Front View

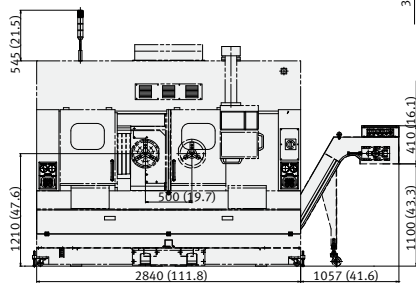

Side View

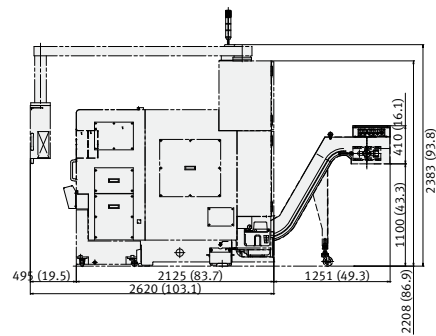

PUMA H230TG

Top View

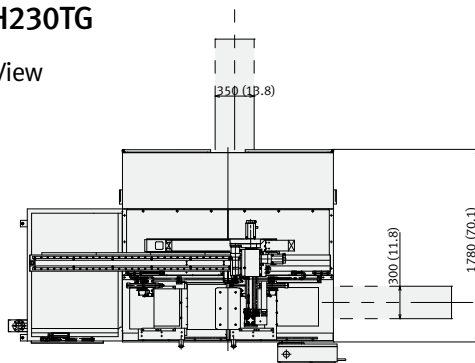

This picture is for A1-type gantry loader application

Front View

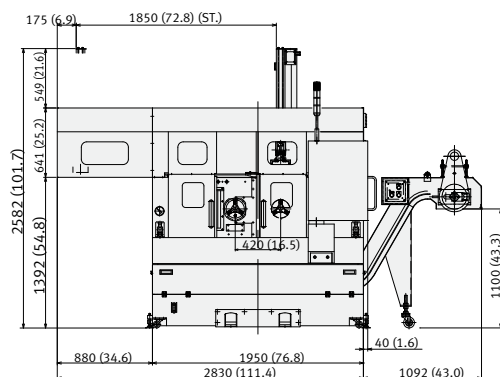

Side View

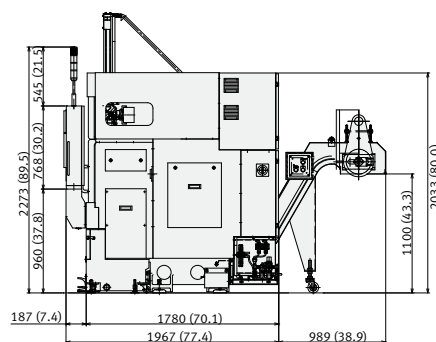

unit : mm (inch)

PUMA QL200H / QL200HM

Top View

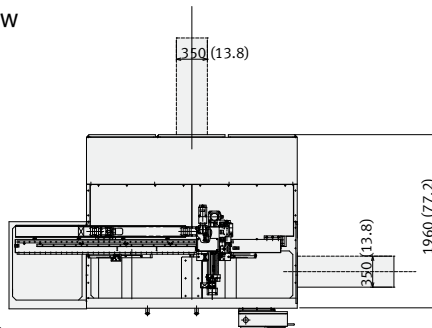

This picture is for A1-type gantry loader application

Front View

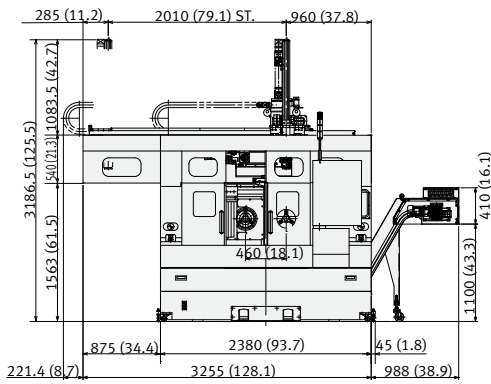

Side View

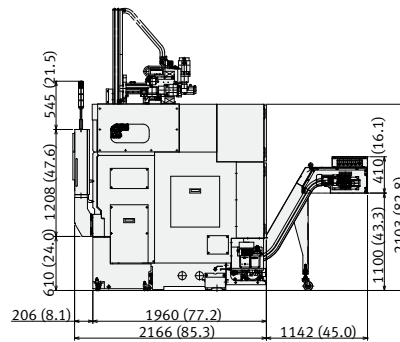

PUMA QL300H / QL300HM

Top View

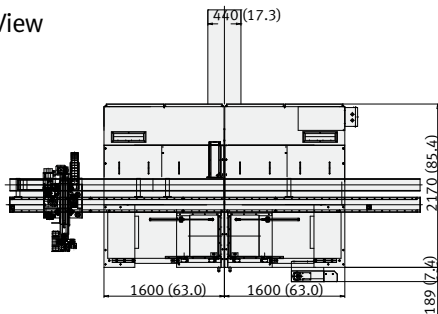

This picture is for A3-type gantry loader application

Front View

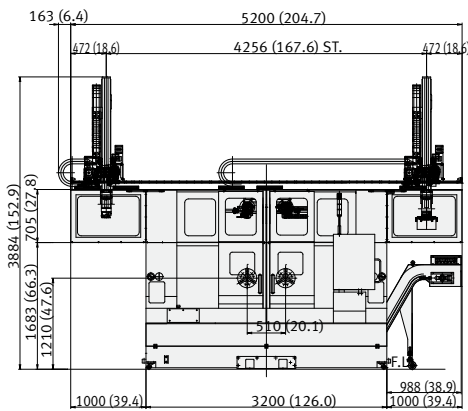

Side View

